



Concurrent Design Method for Product Design of Wheelchair Tiedown and Occupant Restraint Systems (WTORS)

Shih-Wen Hsiao and Sheng-Yi Cheng

EasyChair preprints are intended for rapid dissemination of research results and are integrated with the rest of EasyChair.

December 7, 2020

Concurrent design method for product design of wheelchair tiedown and occupant restraint systems(WTORS)

Shih-Wen Hsiao

Department of Industrial Design
National Cheng Kung University
Tainan, Taiwan
swhsiao@mail.ncku.edu.tw

Sheng-yi Chen

Department of Industrial Design
National Cheng Kung University
Tainan, Taiwan
p37071027@gs.ncku.edu.tw

Abstract—Design objectives orientation is an important indicator of product research and development. Concurrent design Strategy are introduced to coordinate relevant departments to communicate and implement product design processes through clear product design objectives, so that the research and development process can increase efficiency, control costs and reduce risks. This research uses the "Rational method" for product design, excluding the "Perceptual method" black-box design process, and transforms the "black - box" design into the "Transparent-box" design, making the design process transparent and reasonable, and the design results are productive and commercial produce. In this research, we use welcab drivers and wheelchair users to feedback on the use of " Wheelchair Tiedown and Occupant Restraint Systems " (WTORS), using observation methods and researchers' actual operation methods to find product problems, and applying "Objectives tree" Set design objectives, perform product design analysis with "morphology chart method", use "DFMA" design methods for detailed product mechanical design, and use the "DFA" concept to reduce the number of parts, optimize part design, component interference, assembly analysis, to enhance product quality and assembly solution. This research integrates the concurrent design method to quickly combine the design of the "Wheelchair Tiedown and Occupant Restraint Systems" to achieve the design objectives of product safety, fast operation, and reasonable price.

Keywords—Welcab, WTORS, Objectives Tree, Morphological Chart Method, DFA

I. INTRODUCTION

With the continuous advancement of medical technology and the improvement of public health, human life expectancy continues to increase. With the increase in the elderly population, the proportion of people with disabilities in the population of various countries has increased year by year. According to the statistics of the Taiwan Ministry of Health and Welfare, by 2018, the number of people with disabilities is about Taiwan's total population is 5%, and the number of disabled people is about 1.17 million[1]. Therefore, due to medical, school, social, travel and other purposes, the need for people with disabilities to be able to move and move is increasing day by day[2].

The system of assisting wheelchairs and occupants transferred to the vehicle to effectively restrain the wheelchair and occupants is called "Wheelchair Tiedown and Occupant Restraint Systems", hereinafter referred to as WTORS[3], and consists of 2 parts: (1) Wheelchair Tiedown :

In-car wheelchair fixing system,(2) Occupant restraint : where the occupant (wheelchair user) is fixed on the wheelchair. Poorly designed and operated WTORS will not be able to effectively protect the occupants in a car accident or sudden braking of the vehicle. Therefore, designing a set of WTORS quick-combination release system can reduce operating errors and increase the timeliness. It can effectively protect the safety of wheelchair occupants when an accident occurs.

When a wheelchair occupant is hit, if the wheelchair tiedown system or the occupant restraint device fails, it will cause the wheelchair user to overturn or even throw out of the vehicle[4]. The design of this product is aimed at standard and systematic design of WTORS to achieve the following purposes (1) Fast product installation: easy product installation and simple construction. (2) Quick combination of operation: quick combination of wheelchair, saving operation time. (3) Safe use: Standard combined design to ensure the reliability and consistency of WTORS. (4) Ensure that the operation is reliable: simplify the operation process and prevent the equipment operator from using the equipment incorrectly. (5) Improve product reliability: simplify parts and mechanism design to improve durability[5,6].

II. BACKGROUND THEORY

A. Objectives tree

The "Objectives tree" can be used in the execution of different industrial fields or product design projects. The purpose of setting the objectives tree is to use a tree structure to classify product design objectives hierarchically, to clarify the relationship between objectives and sub-objectives, and to target the bottom-level objectives finds out the method to complete the objectives, the steps are as follows: (1) List the main design objectives of the product; (2) Develop different sub-objectives of the product objectives down, and sort them according to high and low levels; (3) Draw the product objectives tree a graph showing the relationship between high and low classes and the methods to achieve each objective.

The design objectives come from customer needs, the company's new development project needs, and the design discussion summary with the team, etc. The simple and clear design objectives are like the rudder function, guiding the designer and the team to carry out the design and design stage review. As the objectives and sub- objectives are listed and arranged in relation to each other, the relationship between each other becomes clear at this time, and the sub- objectives must meet the objectives of the upper level. When the "

objectives tree" is drawn, the product is transformed from a text description into a tree-like objectives diagram. The main objective and sub-objective hierarchical relationship is generated, and the lowest-level objectives need to be given a "method" to achieve the objectives. Therefore, the "objectives tree" is controlled by the main objectives. The relationship between the development of the objective and the previous objective is "how", and the relationship from the secondary objective to the main objective is "why"[7].

B. Morphological chart method

The purpose of "Morphological Chart Method" is to provide a wide range of potential functional solution options, develop different solutions based on product functions or features, and finally select the most suitable product combination, and generate multiple product design proposals for evaluation and discussion[8], the steps are as follows: (1) List the necessary features or functions of the product; (2) List the solutions that can be completed for individual features or functions; (3) Draw a chart of all possible solutions, and display the "morphological chart" A combination of possible solutions; (4) A possible (best) combination plan or sub-combination plan is defined, and the subsequent design process is provided.

After confirming the product design objectives and functions, the "morphological charts method" is one of the design methods for designers (teams) to design ideas and design proposals. When executing the "Morphology Charts method", it is necessary to briefly list the product features or functions, and each is independent and comprehensive, so as to avoid overly lengthy and unnecessary descriptions. "Morphological charts method" can generate a huge number of solution combinations, but these solutions are not all reasonable and executable. The best solution design can be selected through rule of thumb, team evaluation, or design evaluation, or combine different solutions and modify to produce the best design preliminary to meet the design objectives.

C. PUGH concept selection method

Stuart Pugh published the Pugh concept selection method in the 1980s, called the Pugh concept selection method[9]. Its purpose is to quickly screen design concepts and improve them. It is a method often used in design evaluation. Design is a process of divergence and convergence and providing multiple solutions. After divergent conceptual design, the best solution must be converged and selected from many design ideas. PUGH is often used in design selection and non-design decision-making. It can also be used to integrate and optimize finalized design concepts. PUGH's execution procedure has the following four steps:

Step 1: Determine the comparison items: Assign relative weight to the design objectives, and arrange the design objectives from top to bottom in the leftmost row of the matrix as comparison items.

Step 2: List the candidate ideas for design evaluation: Place the candidate ideas at the top of each row of the matrix (column).

Step 3: Set a datum, compare the ideas with the datum for the comparison items listed in step 1, and give a comparison score at the corresponding position of the column and row, the scoring method and score are divided into 5 levels.

Step 4: Calculate the total score of each candidate : After multiplying the individual score of each idea by the weighted

score, the weighted total score of each candidate is obtained. The ranking order can be obtained according to the score ranking, so that the best design idea can be selected.

D. DFA(Design for Assembly)

The purpose of assembly design is to set the appropriate (minimum) number of parts of the product and optimize the parts of the product. By redesigning the product components, it can achieve the best assembly and reduce production costs. The steps are as follows: (1) Assess the efficiency and rationality of individual parts relative to product assembly, (2) Assess the theoretical minimum number of parts with product functions, (3) Optimize parts, evaluate manufacturability and best cost.

The above step (1) is to evaluate the grip, direction, mobility, placement and safety of individual parts. The above step (2) asks the following five questions about the component (1) Does this part need to move relative to other parts in the operating state, that is it cannot perform normal operation without this part, (2) Does this part need to be combined with other parts? The assembled parts are separated or different materials are used, (3) Whether to separate this part from the assembled parts before assembly and maintenance can be carried out, (4) Whether only this part can perform the required function, (5) Due to manufacturing feasibility factors, it is necessary to separate the parts and perform the same function together after assembly. If one of them is met, it means that the part needs to exist separately, so as to ensure the minimum number of product parts.

III. CASE STUDY-DESIGN A PRODUCT OF WTORS

A. Product collection and investigation

Market products are mainly developed countries such as Europe and the United States, Asian countries have developed relatively late in this field, As shown in TABLE I for market product analysis. WTORS wheelchair tiedown methods have 3 types as below[2]:

(1) Strap-type tiedown : Use seat belts and ground anchors to tiedown the wheelchair and the vehicle platform. The advantage is that it is cheap and compatible with different brands of wheelchairs. The disadvantages is that it takes time to construct and tiedown the wheelchair. The wheelchair takes about 120-180 seconds on average to complete the process, and it is easy to endanger the protection of the occupants due to operating errors.

(2) Clamp-type tiedown : Use seat belts and clamps to tiedown the wheelchair and the vehicle platform. The advantage is low price, it can be compatible with different brands of wheelchairs and ground-free anchor construction. The disadvantage is that it takes time to tiedown the wheelchair. It takes about 120-180 seconds on average to complete the process. It is easy to make mistakes in operation and endanger the protection of occupants.

(3) Docking system : The advantage of System is that the construction and the combination of the wheelchair are fast, and it takes about 5 to 10 seconds to finish the combination of the wheelchair. And because the wheelchair is indeed combined, the probability of operation errors is reduced, and the occupant protection ability is effectively improved. The disadvantage is that the wheelchair is heavy and the structure is designed as a single-point fixed wheelchair, high price, etc., this case focuses on the rapid docking system combined with wheelchairs, and improves the shortcomings of this system as the development objectives.

TABLE I. ANALYSIS OF EXISTING PRODUCTS.

Brand	QUICK-SECURE	Stade	QUICK-SECURE	Q'VERADIT	Stade	Stade	Q'VERADIT	
The device type	Loop-type lockers	Loop-type lockers	Loop-type lockers	Loop-type lockers	Loop-type lockers	Docking system	Docking system	
Model name	SMI	S.MI-1	S.MI-2	Q'VERADIT	S.MI-2	SMI-2	Q.S-130	
Sample picture								
Specifications	1. One-hand operation 2. The seat belt is released 3. 1 shaped hook is used to lock the wheelchair 4. Kit + PCS	1. One-hand operation 2. The seat belt is released 3. 1 shaped hook is used to lock the wheelchair 4. Kit + PCS	1. Roll back up 2. The seat belt is released 3. 1 shaped hook is used to lock the wheelchair 4. Kit + PCS	1. Roll back up 2. The seat belt is released 3. 1 shaped hook is used to lock the wheelchair 4. Kit + PCS	1. Roll back up 2. The seat belt is released 3. 1 shaped hook is used to lock the wheelchair 4. Kit + PCS	1. Docking system 2. One-hand operation 3. 1 shaped hook is used to lock the wheelchair 4. Kit + PCS	1. Docking system 2. One-hand operation 3. 1 shaped hook is used to lock the wheelchair 4. Kit + PCS	1. Docking system 2. One-hand operation 3. 1 shaped hook is used to lock the wheelchair 4. Kit + PCS
Advantage	1. Cheap 2. Compatible with all kinds of wheelchair	1. Cheap 2. Compatible with all kinds of wheelchair	1. Relatively cheap 2. Compatible with all kinds of wheelchair 3. Easy to be stored	1. Relatively cheap 2. Compatible with all kinds of wheelchair 3. Easy to be stored	1. Relatively cheap 2. Compatible with all kinds of wheelchair 3. Easy to be stored	1. Wheelchair compatible in front and back 2. One-hand operation 3. The release is simple 4. The Dock is high	1. Wheelchair compatible in front and back 2. One-hand operation 3. The release is simple 4. The Dock is high	1. Wheelchair compatible in front and back 2. One-hand operation 3. The release is simple 4. The Dock is high
Disadvantage	1. Time-consuming operation 2. Time-consuming operation 3. 2 hook combined with wheelchair has standard seat problem	1. Time-consuming operation 2. Time-consuming operation 3. 2 hook combined with wheelchair has standard seat problem	1. Time-consuming operation 2. Time-consuming operation 3. 2 hook combined with wheelchair has standard seat problem	1. Time-consuming operation 2. Time-consuming operation 3. 2 hook combined with wheelchair has standard seat problem	1. Time-consuming operation 2. Time-consuming operation 3. 2 hook combined with wheelchair has standard seat problem	1. Single-point fixed, cannot take 2. The release is simple 3. The release is simple 4. The Dock is high	1. Single-point fixed, cannot take 2. The release is simple 3. The release is simple 4. The Dock is high	1. Single-point fixed, cannot take 2. The release is simple 3. The release is simple 4. The Dock is high

B. Product objectives

According to the user experience method, observation method, inquiry method, and actual operation of the WTORS system, use objectives tree method to set product design objectives. The main objectives are: (1) Rapid product operation, (2) Product safety, (3) Rapid construction, (4) Operation is accurate, (5) Product reliability, the main objectives is to develop sub-objectives according to levels, and so on. The design objectives are: (1) Wheelchair combination and release fast, occupant seat belts fast and reliable, (2) Wheelchair release protection, Multi-point seat belt design, standard combined design, (3) Dock installation is quick and easy, small in size, simple in shape, (4) Reasonable storage mechanism, (5) Easy and simple combined release mode, (6) Solid, the structure is simplified and eventually developed into 13 design objectives, project objectives tree as shown in Fig. 1.

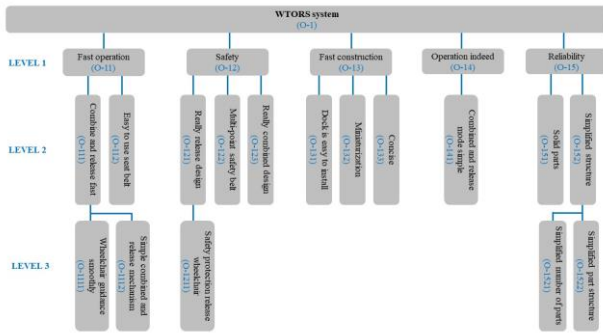

Fig. 1. Objectives tree of product design of WTORS.

C. Establishing Functions and Setting Requirements

In this study, the Transparent box method was used to analyze the WTORS process, and the necessary functions were generated according to the needs of the operation process, and then the "boundary" of the product function was formulated to base the design specifications. The WTORS system wheelchair integration process is (1) the occupants fasten seat belts, (2) Ensure the safety belt, (3) transfer the occupant and wheelchair to the vehicle (using the lift), (4) push the wheelchair and occupant to the WTORS system, (5) the wheelchair combined with the WTORS system, (6) ensure the wheelchair combined, the process is shown in Fig. 2.

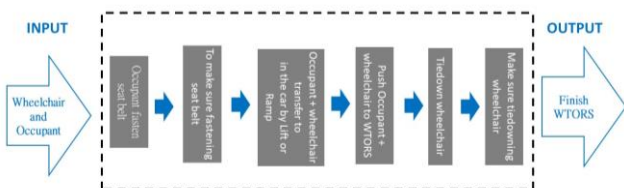

Fig. 2. Transparent-box of WTORS

Develop quantitative product requirements based on the product operation process: (1) Wheelchair Tiedown: Wheelchair Tiedown: less than 10 seconds, product flame resistance rating UL94V0, product height less than 100mm, (2) Occupant restraint: three-point seat belt, tension test greater than 9800N, single-handed after the operation is released, the impact can be released without tools. (3) Product construction: the joint between the device and the vehicle platform is greater than 3 points and must pass the impact test, the dock construction time is less than 30 minutes, and it is suitable for installation in a commercially available welfare vehicle. 4) Product price: product manufacturing cost under USD1,000-1,500, construction cost under USD100-150, (5) product reliability: product service life needs to be more than 10 years and 62,400 times, (6) product safety: crash test compliance ISO10542-1, double system protection of release device, the product requirements is shown in TABLE II.

Define design requirements as below :

- 1)D: is the demand, as the necessary function.
- 2)W: is the wish, as the non-necessary function.

TABLE II. SPECIFICATION FOR PRODUCT OF WTORS.

Type	Specification for Product of WTORS		
	Requirements	D and W	Responsible
Wheelchair Tiedown	1. Time of Wheelchair tiedown under 10 seconds	W	
	2. Product flame resistance rating UL94V0	D	
	3. Product height under 100mm	W	
Occupant restraint	1. Over three-point seat belt, tension test more than 9800N	D	
	2. One-handed operation and release	W	
	3. It can be released without tools after impact	D	
Product construction	1. There are more than 3 places where the equipment and the vehicle platform are fixed, and the impact test is required.	D	
	2. Construction time under 30 minutes	W	
	3. Suitable for installation on most welfare vehicles: (1) Mitsubishi: Delica, (2) VW: T6/Caddy, (3) Ford: touano custom, (4) TOYOTA: Granvia / Hiace / Alphard, (5) HYUNDAI: STAREX, (6) Benz: Vito	W	
Product price	1. Product manufacturing cost under USD1,000 to 1,500	W	
	2. Construction cost under USD100-150	W	
product reliability	1. Product life: 10 years/62,400 times, base on 20 times (every day) x 5 days (weekly) x 52 (week) x 10 (year) x 1.2 (safety factor).	D	
	2. Release device safety protection	D	

D. Generating Alternatives

Apply morphological chat methods to implement product concept development. According to product specifications, it is set as: (1) Wheelchair safety belt, (2) Wheelchair storage, (3) Wheelchair and dock combination mechanism, (4) Wheelchair release mechanism, (5) Dock and car Platform combination, (6) Wheelchair and dock combined guidance, and develop all possible solutions based on this function, as shown in TABLE III. Evaluate the best (suitable) solution for each function according to the concept development, and generate 3 development combinations in series, as shown in Fig. 3. After screening the proposals, they are organized as follows, as shown in Fig. 4.

- (1) Idea A: A2+B2+C1+D1 +E2+F2
- (2) Idea B: A3+B1+C2+D2+E1+F1
- (3) Idea C: A1+B1+C2+D1+E1+F3

TABLE III. MORPHOLOGICAL CHARTS OF WTORS

Solutions	1	2	3
A Wheelchair seat belt	A1 2-point safety belt (by wheelchair)	A2 3-point safety belt (by wheelchair)	A3 3-point safety belt (by car)
B Wheelchair storage	B1 Not collapsible	B2 Collapsible	
C Wheelchair and Dock combination mechanism	C1 Fix on both sides of the wheelchair	C2 Fix on middle of the wheelchair	
D Wheelchair release mechanism	D1 Foot pedaling Release wheelchair	D2 Hand lever Release wheelchair	
E Dock combined with car platform	E1 4 point fixed (Outside the Dock)	E2 4 point fixed (Inside the Dock)	E3 3 point fixed (Outside the Dock)
F Wheelchair and Dock guidance	F1 C-shaped guided wheelchair	F2 R-shaped guided wheelchair	F3 Tapered guided wheelchair

Subfunctions	Solutions		
	1	2	3
A Wheelchair seat belt	A1 2-point safety belt (by wheelchair)	A2 3-point safety belt (by wheelchair)	A3 3-point safety belt (by car)
B Wheelchair storage	B1 Not collapsible	B2 Collapsible	
C Wheelchair and Dock combination mechanism	C1 Fix on both sides of the wheelchair	C2 Fix on middle of the wheelchair	
D Wheelchair release mechanism	D1 Foot pedaling Release wheelchair	D2 Hand lever Release wheelchair	
E Dock combined with car platform	E1 4-point fixed (Outside the Dock)	E2 4-point fixed (Inside the Dock)	E3 3-point fixed (Outside the Dock)
F Wheelchair and Dock guidance	F1 C-shaped guided wheelchair	F2 R-shaped guided wheelchair	F3 Tapered guided wheelchair

Fig. 3. 3 ideas combinations of WTORS

Subfunctions	Solutions	IDEA 1			IDEA 2			IDEA 3		
		S1	S2	S3	S1	S2	S3	S1	S2	S3
A Wheelchair seat belt	A1 2-point safety belt (by wheelchair)	A2 3-point safety belt (by wheelchair)	A3 3-point safety belt (by car)	A1 2-point safety belt (by wheelchair)	A2 3-point safety belt (by wheelchair)	A3 3-point safety belt (by car)	A1 2-point safety belt (by wheelchair)	A2 3-point safety belt (by wheelchair)	A3 3-point safety belt (by car)	
B Wheelchair storage	B1 Not collapsible	B2 Collapsible		B1 Collapsible	B2 Collapsible		B1 Collapsible	B2 Collapsible		
C Wheelchair and Dock combination mechanism	C1 Fix on both sides of the wheelchair	C2 Fix on middle of the wheelchair		C1 Fix on both sides of the wheelchair	C2 Fix on middle of the wheelchair		C1 Fix on both sides of the wheelchair	C2 Fix on middle of the wheelchair		
D Wheelchair release mechanism	D1 Foot pedaling Release wheelchair	D2 Hand lever Release wheelchair		D1 Foot pedaling Release wheelchair	D2 Hand lever Release wheelchair		D1 Foot pedaling Release wheelchair	D2 Hand lever Release wheelchair		
E Dock combined with car platform	E1 4-point fixed (Outside the Dock)	E2 4-point fixed (Inside the Dock)		E1 4-point fixed (Outside the Dock)	E2 4-point fixed (Inside the Dock)		E1 4-point fixed (Outside the Dock)	E2 4-point fixed (Inside the Dock)		
F Wheelchair and Dock guidance	F1 C-shaped guided wheelchair	F2 R-shaped guided wheelchair		F1 C-shaped guided wheelchair	F2 R-shaped guided wheelchair		F1 C-shaped guided wheelchair	F2 R-shaped guided wheelchair		

Fig. 4. 3 ideas organization of WTORS

E. PUGH Evaluation Design Alternatives

For each level of the objectives tree level 1, level 2, and level 3, use the ranking-order method to assign weights to the design objectives, as shown in TABLE IV, V, VI. According to the 3 best design proposals developed by the morphological chart method, the PUGH concept is selected, and the ranking result is IDEA A>IDEA B>IDEA C, and finally IAED A is selected for engineering design based on the quantitative comparison results. The evaluation process and results are as shown in TABLE VII.

TABLE IV. LEVER 1 OF WEIGHTTD OBJECTIVES

Level 1	O-11	O-12	O-13	O-14	O-15	SUM	Weight	Remark
O-11	—	1	4	2.5	2	9.5	0.19	
O-12	4	—	4	3	2.5	13.5	0.27	
O-13	1	1	—	1	4	7	0.14	
O-14	2.5	2	4	—	2.5	11	0.22	
O-15	3	2.5	1	2.5	—	9	0.18	
SUM						50	Total 1.0	

TABLE V. LEVER 2 OF WEIGHTTD OBJECTIVES

Level 2 O-11	O-111	O-112	SUM	Weight	Level 2 O-12	O-121	O-122	O-123	SUM	Weight
O-111	—	3	3	0.6	O-121	—	2.5	2.5	5	0.33
O-112	2	—	2	0.4	O-122	2.5	—	3	5.5	0.37
SUM			5	Total 1.0	O-123	2.5	2	—	4.5	0.3
Level 2 O-13	O-131	O-132	O-133	SUM	Weight	Level 2 O-14	O-141	O-142	SUM	Weight
O-131	—	4	4	8	0.53	O-141	—	2.5	2.5	0.5
O-132	1	—	2	3	0.2	O-142	2.5	—	2.5	0.5
O-133	1	3	—	4	0.27	SUM			5	Total 1.0
SUM				15	Total 1.0					

TABLE VI. LEVER 3 OF WEIGHTTD OBJECTIVES

Level 2 O-111	O-1111	O-1112	SUM	Weight	Level 2 O-152	O-1521	O-1522	SUM	Weight
O-1111	—	2	2	0.4	O-1521	—	2.5	2.5	0.5
O-1112	3	—	3	0.6	O-1522	2.5	—	2.5	0.5
SUM			5	Total 1.0	SUM			5	Total 1.0

TABLE VII. PUGH EVALUATE DESIGN IDEAS

Objectives	Weight	Concepts					
		Idea-A		Idea-B(Drum)		Idea-C	
		Rating	Weighted Score	Rating	Weighted Score	Rating	Weighted Score
1. Wheelchair guidance smoothly	0.04	3	0.12	3	0.12	4	0.16
2. Single combined and release mechanism	0.07	4	0.28	3	0.21	3	0.21
3. Easy to use seat belt	0.08	4	0.32	3	0.24	3	0.24
4. Safety protection release wheelchair	0.09	4	0.36	3	0.27	3	0.27
5. Multi-point safety belt	0.10	3	0.3	3	0.3	1	0.1
6. Really combined design	0.08	3	0.24	3	0.24	3	0.24
7. Dock is easy to install	0.07	3	0.21	3	0.21	3	0.21
8. Maintenance	0.03	4	0.12	3	0.09	3	0.09
9. Costless	0.04	4	0.16	3	0.12	3	0.12
10. Combined and release mode step	0.22	3	0.66	3	0.66	3	0.66
11. Solid parts	0.09	3	0.27	3	0.27	3	0.27
12. Simplified number of parts	0.045	2	0.09	3	0.135	3	0.135
13. Simplified part structure	0.045	2	0.09	3	0.135	3	0.135
Total Score			3.22		3		2.84
Rank			1		2		3
Continue			Develop				

5:Much better
4:Better
3:Same
2:Worse
1:Much worse

F. Engineering Design

Based on the design objectives, design specifications and morphological chart, the best design proposal is conceived and developed, using 3D CAD tools, DFM and DFA as the concept, to evaluate product functionality, manufacturability, adaptability, cost factors, transportation packaging, etc. Give parts materials, surface treatments, 3D functions and parts dimensions to perform engineering design. The engineering design results are as follows: (1) Dock shape and mechanism design, dimensions as shown in Fig. 5, (2) Wheelchair shape and mechanism design, (3) Wheelchair 3-point safety belt design. The design results are followed by product development procedures such as sample making, design verification, design adjustment, trial production, trial mass production, and mass production. Combination of wheelchair and dock as shown in Fig. 6,7, product exploded view and BOM as shown in Fig. 8.

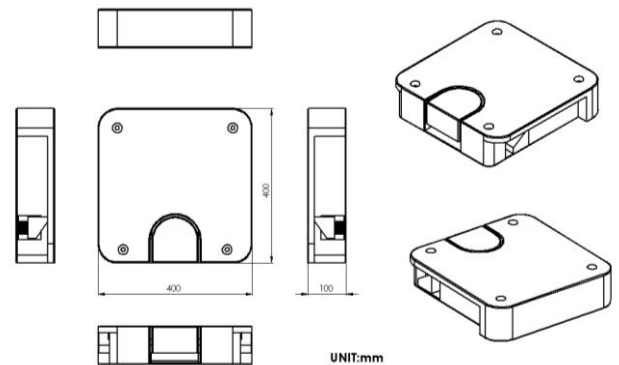

Fig. 5. Design and dimension of Dock

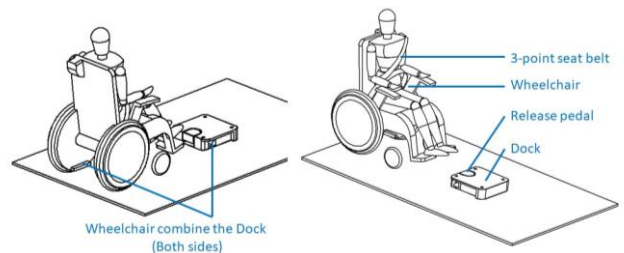

Fig. 6. Before combining Wheelchair and Dock

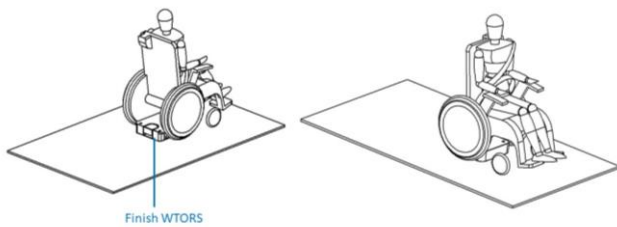

Fig.7 . Finish WTORS system

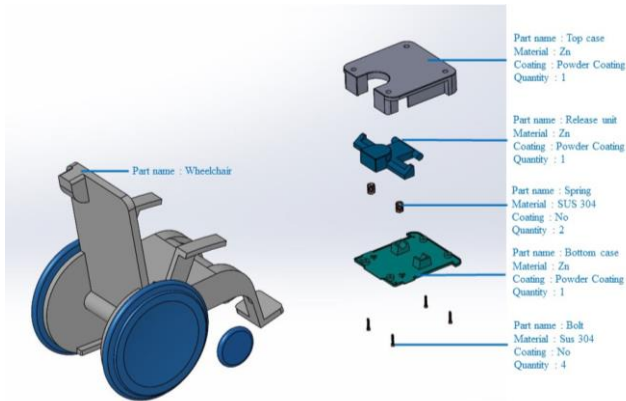

Fig.8 . Product explode and BOM

IV. DISCUSSION AND RESULTS

The author serves company that research, manufacture, and modify barrier-free vehicles, and also operates transportation services for people with disabilities. Therefore, there are many opportunities for in-depth discussions and feedback with wheelchair users and WTORS operators to find out the advantages and disadvantages of the product. In addition, the author has a better understanding of the existing problems and market niches of the WTORS system through actual operation of the product and observation.

This research case can obtain the following clear research results and data: (1) In line with market analysis and research, WTORS design products can be commercialized. (2) Three proposals for concept development, (3) 3D model construction of feasible solutions for concept development one item, (4) One engineering drawing, including parts drawing, product assembly drawing, exploded drawing, and parts bill of materials (BOM).

V. CONCLUSION

Using the concurrent design method and rational methods for product design has the advantage of systematically

developing the design process and recording the process and results[10], so that information can be effectively managed and applied. This research integrates "Objectives tree method", "Transparent box method", "morphological chart method" and other methods in the product design of WTORS. The purpose is to find "product opportunities" through market product research, so as to formulate a objectives tree to clarify product design objectives. Guide the design to clearly implement the design objectives, use the transparent box method to analyze the product operation process to develop product specifications, adopt product specifications to meet user and market needs, apply morphological chat methods to develop functional requirements solutions, and obtain the best product design solution Finally, the engineering design stage for mechanism design. Using DFA concept design and analysis for engineering design, this method will ensure that the product parts reach the minimum number and the best component optimization. The results of this study found that the program conversion design process is rigorous and rational. The results are mass-produced, the products are marketable, and the design information can be completely retained. It is hoped that the industry and academia can exchange experience and apply research with each other.

REFERENCES

- [1] Ministry of Health and Welfare, Taiwan Executive Yuan, Country statistics bulletin, Taiwan, 2019(in chinese).
- [2] Chin-Cheng Kuo, Safety of vehicle wheelchair and its restraint system, Automotive Research & Testing Center, Newsletter, 2017(in chinese).
- [3] Shang-Rung Shih, Traffic vehicle wheelchair dynamic safety test, Automotive Research & Testing Center, Newsletter, 2011(in chinese).
- [4] Gu. Jun, "Dynamic impact testing and computer simulation of wheelchair tiedown and occupant restraint systems (WTORS)", PhD thesis, Middlesex University, 1999.
- [5] Boothroyd. G., Dewhurst. P., Product Design for Assembly. Boothroyd Dewhurst, Inc., Wakefield, 1991.
- [6] Shih-Wen Hsiao, Cheng-Wei Fan, Application research of integrating FSM, STM, DFA method in faucet design, Journal of the Chinese Institute of Industrial Engineer,13, 225-235,1996.
- [7] Cross, Nigel, Engineering Design Methods, strategies for Product Design, Fourth Edition, John Wiley & Sons, Ltd, England, 2008, cp. 6,sec. 1, p77-91.
- [8] Cross, Nigel, Engineering Design Methods, strategies for Product Design, Fourth Edition, John Wiley & Sons, Ltd, England, 2008, cp. 10,sec. 1, p137-149.
- [9] Yong-Bin Li, Ting Chen, Quan-Pan Liang, Pugh Concept Selection Method Applied Research in Product Design, Packaging engineering, Issue 10, pp. 167-172, 2018(in chinese).
- [10] S. W. Hsiao and T. P. Yuan, "Concurrent design strategies for developing a portable pour-over coffee maker," Journal of design studies, vol. 1, no. 1, pp. 20-31, 2016.