



Positively shifting the mindset in construction:
Using Non - Biodegradable materials for
sustainable construction

Faheem Memon

EasyChair preprints are intended for rapid dissemination of research results and are integrated with the rest of EasyChair.

February 26, 2020

Positively Shifting the Mindset in Construction: Using Non - Biodegradable Materials For Sustainable Construction

Author 1

- Faheem Memon
- Heriot-Watt University UK
- 0000-0003-4820-8508

Abstract

Disposing of the non-biodegradable material, scrap Tyre rubber specifically, has always been a bone of contention for the municipalities around the world. Not only the land that it covers is the major issue, but also the environment is always at risk because the scrap tyre being non-biodegradable, takes ages in decomposition. It is always prone to fire, which may cause a disastrous situation around as it is not so easy to extinguish the scrap tyre fire by whatever the resources available to the firefighters. To deal with this modern-day issue which rapidly became a serious concern of many governments in terms of social, economic & environmental sustainability, many researches started working on the effective use of scrap tyre rubber by using it in different infrastructure elements, for instance, road pavements, waterproofing of underground utilities, shotcrete for tunnel wall lining, floor coverings of the playgrounds. Keeping in mind the sustainability issues, this study was conducted to assess the change in the fundamental structural properties of the concrete by mixing scrap tyre rubber as an additive material. Four batches of the concrete were designed to be tested in the laboratory with the first batch as plain concrete with no scrap tyre rubber to be kept as a reference point, 10%, 20% and 30% addition of scrap tyre rubber by weight of cement. Results showed drastic improvement in Cylinder Crushing Strength, Modulus of Elasticity, the Poisson's ratio and the Ultimate Flexural Strength of beams.

Keywords chosen from ICE Publishing list

Fibre-reinforced concrete; Tensile properties; Strain

List of notations (examples below)

E	is the elastic modulus of the concrete
ν	is the Poisson's ratio
C_m	is the Elastic limit stress
$A.M.S$	is the Axial MicroStrain
$L.M.S$	is the Lateral MicroStrain
S_1, S_2, S_3, S_4	are the Strain readings at different loadings

Introduction

Fibre-reinforced concrete is a composite material consisting of cement paste, mortar or concrete with the fibre of asbestos, glass, plastic, polypropylene, steel etc. such a fibre reinforcement may be useful under explosive loading where high strength in tension zone and reduced hair cracking is desired. Different fibres are used for reinforcing concrete and still research is underway to introduce some new and better ones.

Steel (carbon, stainless), glass (alkali-resistant) has a higher value of elastic moduli, and they contribute both to impact resistance and to flexural strength. Again, natural fibres like asbestos and vegetable fibres and polypropylene improve impact resistance but flexural strength may remain unaffected. A few of the advantages of such type of concrete are; high tensile and impact resistance, high compressive strength, very good and satisfactory flexural strength, increase in ultimate load carrying capacity, improvement of ductility, shear strength, torsion strength, splitting resistance, bearing strength, resistance against wear and abrasion, high resistance to freezing and thawing and fatigue loading.

The compressive strength of concrete is very high but due to its brittleness, it cannot resist sufficient tensile stress. Therefore, steel bars are used to strengthen concrete in situations where tensile stresses are developed. Another form of reinforcement is random dispersal of short, discontinuous and discrete fine fibres called fibre reinforcement. The fibre can be imagined as an aggregate with an extreme deviation in shapes from the rounded smooth aggregate. The fibres interlock and entangle around aggregate particles and considerably reduce the workability while mix becomes more cohesive and less prone to segregation. The fibre suitable for reinforcing the concrete has been produced from steel, glass and organic polymers.

In contrast to reinforcing bars in reinforced concrete which are continuous and carefully placed in the structures to optimize their performance, the fibres are discontinuous and are generally randomly distributed throughout the concrete matrix. Thus, the reinforcing performance of steel fibres, for example, is inferior to that of reinforcing bars. Also, the fibres are likely to be more expensive than conventional steel bars, thus, fibre reinforced concrete is not likely to replace conventional reinforced concrete. However, the addition of fibres makes the conventional plain concrete more versatile, more flexible in method of

production and more competitive as a construction material.

Essentially, fibres act as crack arrestors, restricting the development of cracks and thus transforming an inherently brittle matrix, i.e., Portland cement with its low tensile and impact resistances into a strong composite with superior cracks resistance, improved ductility and distinctive post-cracking behaviour before failure. Steel fibres are probably the best suited for structural applications. Due to the superior properties like increased tensile and bending strengths, shear and torsional strengths, improved ductility, resistance to cracking, high impact strength and toughness, spalling resistance and high energy absorption capacity, fibre-reinforced concrete has found special application in hydraulic structures, airfield pavements highways, bridge decks, heavy-duty floors and tunnel linings.

Since all the types of fibre tried so far are quite expensive to achieve economy of construction but without sacrificing the better and improved strength properties of fibre reinforced. The study that is being presented in this paper has an enhanced scope of the addition of scrap tyre rubber with normal concrete consisting of Ordinary Portland Cement, hill sand and coarse aggregates.

2. Literature review

In general, the concrete used with fibre reinforcement requires higher cement concrete, lower coarse aggregate content and smaller size of coarse aggregate. A very large number of investigators have conducted systematic research on various aspects of fibre reinforced concrete for more than three decades. A few of application areas in which significant field trials took place include overlays for bridge decks and pavement (highway and airfield), mining and tunnelling application, slope stabilization, refractory application, concrete repair, industrial floors and precast concrete products.

(Samarrai, Mufid A. & Elvery Robert H, 1974) studied experimentally the influence of fibres upon crack development in reinforced concrete subject to uniaxial tension

(Samarrai, Mufid A. & Elvery Robert H, 1974). (Raja Gopalan et al., 1974) studied the effect of steel fibres on the strength of concrete beams. Aligned continuous fibres, aligned discontinuous fibres and random discontinuous fibres were within the domain of their extent of experimental investigations. The durability of fibre with the cement matrix is one

of the most important aspects. Therefore, (Hannant et al., 1975) undertook to assess experimentally the resistance of steel fibre to corrosion in normal weight and lightweight concrete cylinders in the cracked state and also studied the performance of fibres in normal grade concrete beams exposed after initial loading which induced cracks with widths of 0.1 mm to 0.3mm. The cylinders were placed on three sites covering relatively mild exposure, marine conditions and polluted industrial atmosphere. Observation for 4.75 years suggests that the corrosion of fibres within the concrete is unlikely to cause major problems. The cracked beams were exposed to the marine environments for eleven months during which significant carbonation and fibre corrosion occurred. The failure loads of the specimens tested at this age did not decrease below the initial cracking loads. The failure of steel fibre reinforced concrete composites is generally attributed to the failure of the bond between fibres and matrix. Thus, the strength of the fibres is not fully utilized. Attempts have been made to improve the efficiency of fibre reinforcement by increasing the shear strength of the fibre-matrix interface by chemical or mechanical means as well as by aligning the fibres in the direction of the principal tensile stress. The influence of increased bond strength by chemical or mechanical means is generally measured by a pull-out test on a single fibre. The peak load required to pull out fibre is often expressed at average bond strength by dividing its value by the embedded surface area. The post cracking tensile strength of fibre reinforced concrete has been studied by (D.A.Gasparini et al., 1989). (George Nammur et al., 1989) investigated the bond stress for fibre reinforced concrete based on the bond stress-slip relationship.

3. EXPERIMENTAL DETAILS

The behaviour of concrete is affected by different parameters. Therefore, before starting the project it is necessary to decide the parameter of the study. Since, it is supposed to compare the properties of the concrete, mixed with different proportions of fibre fragments, hence the percentage of fibre fragments in the mix is kept as variable and all other parameters as fixed. Tyre fibres with Approximate dimension of 40x2x2 mm from the sidewall of the scrap tyre were prepared for the study reason.

3.1. The ratio of Tyre fibre

It is expected that Tyre fibre scrap would increase the strength of concrete with an

increase of percentage in mix. So, the ratio of 10% to 30% of tyre fibre is used.

In this regard, a standard mix with a design strength of 15 N/mm² is taken and the effect of the ratio of Tyre fibre added as reinforcement, on the fundamental structural properties have been investigated. The ratio of this fibre is 10% to 20% to 30% by weight of the cement. The tyre fibre is added randomly during the mixing of the ingredients of the fresh concrete.

3.2. Mix Proportions

To get comparable results, any type of concrete can be used, e.g., Normal concrete (i.e., with fine and coarse aggregates) or micro concrete (i.e., with fine aggregate only). For this study, normal concrete is used, prepared with fine sand (i.e., red hill sand) passed through No: 16 sieve and coarse aggregate passed through 10 mm sieve mixed with cement and potable water. The ratio of mix is kept as 1: 2: 4: by weight (i.e., 1 for cement, 2 for and 4 for coarse aggregate) and w/c ratio is 0.5.

3.3. Compaction

The compaction of concrete may result in large variations between selected batches, if not maintained properly. The compaction is usually done by table vibrators in the laboratories. In our structures laboratory, the available vibrator is table type and its maximum intensity is 10 oscillation/min.

To get the same degree of compaction in all the batches, the vibrator was maintained at 5 oscillation/min. and kept it on for 20 minutes.

3.4. Curing

As discussed earlier in detail, that the strength of concrete increases with age if properly cured. Since for design purposes, 28-day strength is used, therefore, all the batches were submerged in the pond for 28-days.

3.5. Cubes

Cubes are used for determining crushing (compressive) strength of concrete. However, they contribute to determining the modulus of elasticity and Poisson's ratio too. The latest size as prescribed by BS 1881 is 100mm x 100mm x 100mm. Due to the restraining effects of platens, it is expected that the results obtained at such size are more reliable than any other size at uncharged factors.

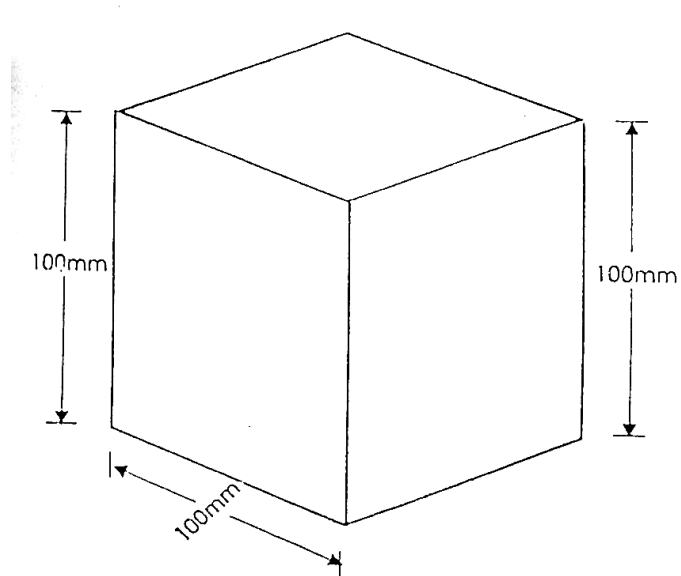

Figure 1: Dimensions of a Cube

3.6. Cylinders

Cylinders are used especially for determining the indirect tensile strength tests, and on the other hand, they help a lot to determine the modulus of elasticity. Cylinders give tensile strength by using cylinders of 150 mm height and 75mm diameter.

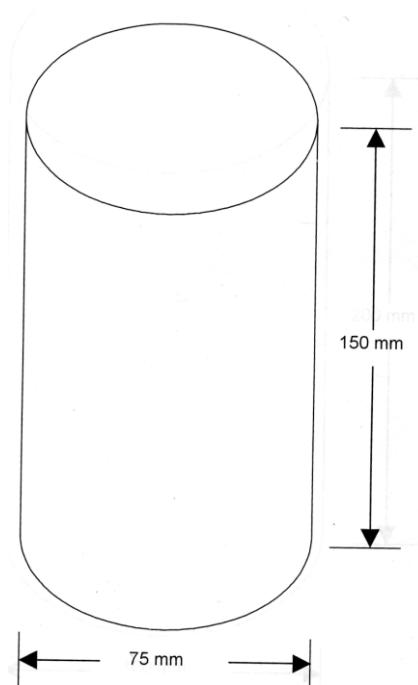

Figure 2: Cylinder Dimensions

4. EXPERIMENTAL PROCEDURE

The experimental procedure is different for different types of tests. For this study, different

tests were performed and various purposes served by these tests are as follows;

4.1. Compression Tests for Crushing Strength

For compression tests, the cube is concentrically placed between the platens of universal load testing machine and then load is applied gradually till the cube is crushed. The ultimate load at the crushing failure is divided by the cross-sectional area of the cube to give ultimate compressive stress. At least three cubes from each batch are crushed and tested for values. Average of the three is taken as the representative value of ultimate compressive stress.

4.2. Test for Modulus of Elasticity

4.2.1. Immediately before the test, the cube crushing strength of concrete is determined and one-third of the value is taken as C_m , i.e. Elastic limit stress. DEMEC pads are stuck on the opposite sides of cylinder specimen with the help of Magic Depoxy steel (or Araldite) in such a fashion that gauge points are symmetrically about the middle of the specimen. DEMEC gauge is used to measure the strain at different loading stages.

4.2.2. Initially, no-load readings of the gauge are noted and this specimen is placed under compression in the universal load testing machine, the load is gradually applied up to (C_m). The load is maintained here for one minute approximately and DEMEC gauge readings are measured on either side of the specimen. The load is then released to measure the strain values again before the second step of loading.

4.2.3. The load is then reapplied at the same rate until the average stress of ($C_m + 1$) is reached. Strains are measured once again and load is hold up till the gauge readings are taken safely. The no-load readings are again noted after releasing loads.

4.2.4. The load is applied once again at the same rate and strains are measured at a point when the average stress of ($C_m + 2$) is reached and after releasing the load, the value of strain is measured.

4.2.5. The load is applied fourth time at the same rate and DEMEC gauge readings are taken in approximately ten equal increments of stresses up to (C_m).

Modulus of elasticity, $E = \frac{\text{Stress}}{\text{Strain}}$

Where Poisson's Ratio, $\nu = \frac{\text{Lateral micro strain}}{\text{Axial micro strain}}$

For each case and finally the average of all, represent the actual modulus of elasticity for that particular concrete mix.

4.3. Test for Poisson's Ratio

Tests for Poisson's ratio are performed on cubes, keeping in mind the principle that axial strain is always accompanied by lateral strain. For the very purpose, DEMEC pads are stuck on two opposite sides of the cube in a set of four, two are horizontal and two are vertical. They are kept at the same distance from the centre of the cube. The strain gauge readings are measured horizontal and vertically simultaneously for lateral strain and axial strain respectively.

The load is applied in the same manner as was done for the computation of modulus of elasticity.

$$\text{Poisson's Ratio, } \nu = \frac{\text{Lateral micro strain}}{\text{Axial micro strain}}$$

5. General Description

In all Twelve Cubes were tested for 4 batches of concrete with 0%, 10%, 20% & 30% tyre rubber.

Poisson's Ratio, as well as Cube crushing strength, were determined. Twelve Cylinders were tested to find the modulus of elasticity and cylinder crushing strength. Four beams with no reinforcement Steel bars were tested by applying a single point load at the centre. The effective span of the beam was 900mm and the load was applied gradually with small increments till failure; the purpose was to determine tensile strength and its improvement due to the presence of Tyre rubber.

6. Compressive Strength

All cubes were crushed by applying load gradually with using Forney Universal Load Testing Machine the strain in axial as well as the lateral direction was measured using demec gauge. Those results are presented in tables 5.1 to 5.6, while stress-strain is presented below.

0 % TYRE FIBRE

Table 6.1

S. #	Load	Stress	S ₁	S ₂	A. M. S	S ₃	S ₄	L.M.S
1	0	0	0	0	0	0	0	0
2	14362	1.43	-7	-199	-2060	9	30	210
3	20053	2.00	-10	-209	-2190	3	33	300

4	30170	3.01	-10	-206	-2240	0	30	300
5	39926	3.99	-18	-220	-2500	18	33	120
6	50060	5.00	-30	-239	-2730	0	30	60
7	63116	6.31	-34	-318	-3956	5	9	290
8	72084	7.20	-77	-319	-3700	2	29	350
9	80756	8.07	-51	-359	-5490	3	30	310
10	89790	8.97	-100	-388	-5050	12	29	410
11	101350	10.13	-117	-371	-508	13	3.8	250
12	110200	11.02	-137	-379	-6360	35	13	640
13	120140	12.01	-257	-388	-9170	62	51	1920
14	130160	13.01	-529	-421	-4130	72	157	4860
15	140910	14.09	-692	-488	-12180	73	424	7920
16	150220	15.02	-730	-521	-14100	93	820	
17	160010	16.00	-839					

$$160010/3 = 53336$$

$$\nu = \frac{\text{Lateral micro stain}}{\text{Axial micro Strain}}$$

$$= \frac{60}{2730}$$

$$= 0.022$$

Since the value is un-expectedly too small, this may be discarded.

10 % TYRE FIBRE

Table 6.2

S. #	Load	Stress	S ₁	S ₂	A. M. S	S ₃	S ₄	L.M.S
1	0	0	0	0	0	0	0	0
2	10026	1.00	-18	-93	-1110	42	33	90
3	20234	2.02	-39	-23	-620	18	64	460
4	30229	3.02	-29	-13	-420	28	3	310
5	40300	4.03	-21	-244	-2650	52	20	720
6	50134	5.03	-39	-150	-1890	38	32	700
7	60320	6.03	-49	-190	-2390	29	3	320
8	70412	7.04	-56	-195	-2510	90	15	170
9	80300	8.03	-61	-200	-2010	2	43	280
10	90151	9.01	-99	-245	-3340	71	38	380
11	100440	10.04	-141	-280	-4210	35	34	980
12	110290	11.02	-166	-287	-4530	132	32	140
13	120140	12.01	-229	-339	-5680	178	57	1800
14	130390	13.03	-235	-384	-6190	123	4	340
15	140100	14.01	-242	-402	-6440	352	125	5360
16	150220	15.02	-248	-417	-6650	411	156	4970

$$160240/3 = 53413$$

$$\nu = \frac{\text{Lateral micro stain}}{\text{Axial micro Strain}}$$

$$= \frac{700}{1890}$$

= 0.37

10 % TYRE FIBRE

Table 6.3

S. #	Load	Stress	S ₁	S ₂	A. M. S	S ₃	S ₄	L.M.S
1	0	0	0	0	0	0	0	0
2	10117	1.01	-10	-25	-350	14	19	430
3	20221	2.02	-12	-23	-350	14	23	9
4	30170	3.01	-34	-20	-540	10	30	200
5	40168	4.01	-49	-23	-720	16	46	620
6	50134	5.01	-79	-30	-1090	24	29	530
7	60070	6.00	106	-28	-1340	16	10	60
8	70007	7.00	-172	-26	-1980	8	5	130
9	80034	8.00	-185	-38	-147	23	10	330
10	90151	9.01	-200	-14	-2140	38	16	540
11	100080	10.00	-262	-11	-2730	75	23	980
12	110020	11.00	-349	26	-3320	106	33	1390
13	120050	12.00	-382	-1	-3830	113	46	1590
14	130070	13.00	-412	-25	-4370	125	58	1830
15	140100	14.01	-449	-28	-4770	140	66	2120
16	150735							

150735/3 = 50245

$\nu = \frac{\text{Lateral micro stain}}{\text{Axial micro Strain}}$

$$= \frac{530}{1090}$$

= 0.486

10 % TYRE FIBRE

Table 6.4

S. #	Load	Stress	S ₁	S ₂	A. M. S	S ₃	S ₄	L.M.S
1	0	0	0	0	0	0	0	0
2	10117	1.01	-152	-4	-1500	70	18	88
3	20053	2.00	-171	-19	-1900	52	23	750
4	30170	3.01	-221	-24	-2450	64	37	1010
5	41010	4.10	-221	-39	-2600	51	38	890
6	50230	5.02	-239	-62	-3010	60	28	880
7	60070	6.00	-250	-71	-3210	81	15	960
8	70079	7.00	-170	-81	-2510	90	58	1480
9	80756	8.07	-209	-87	-2960	90	65	960
10	90783	9.07	-263	-112	3750	31	67	1160
11	100080	10.00	-271	-150	-4210	49	38	600
12	110650	11.06	-330	-151	-4810	22	18	390
13	120500	12.05	-300	-129	-4290	21	72	1120
14	130070	13.00	-330	-157	-4870	40	62	1110
15	140100	14.01	-319	-166	-4850	49	48	1150
16	150220	15.02	-387	-174	-5610	67	60	1400
17	160060	16.00	-380	-189	-5690	80	65	1550
18	170360	17.03	-394	-227	-6210	90	77	1700
19	180030	18.00	-412	-260	-6720	93	81	1850
20	190245							

190245/3 = 63415

$\nu = \frac{\text{Lateral micro stain}}{\text{Axial micro Strain}}$

$$= \frac{960}{3210}$$

$$= 0.29$$

20 % TYRE FIBRE

Table 6.5

S. #	Load	Stress	S ₁	S ₂	A. M. S	S ₃	S ₄	L.M.S
1	0	0	0	0	0	0	0	0
2	10202	1.02	-1	-84	-850	7	8	150
3	19936	1.99	-20	-85	-950	20	18	380
4	30080	3.00	-30	-94	-1240	47	28	28
5	40107	4.01	-119	-110	-2290	71	29	1000
6	50043	5.00	-120	-186	-3060	77	30	1070
7	59980	5.99	-137	-116	-2530	80	35	1150
8	70320	7.03	-141	-121	-2620	130	38	1680
9	80034	8.00	-147	-146	-2930	160	40	2000
10	90303	9.03	-172	-147	-3190	170	48	2180
11	99907	9.99	-213	-151	-3640	170	68	2380
12	110020	11.00	-250	-153	-4030	172	71	2430
13	120590	12.05	-252	-164	-4160	174	80	2540
14	130070	13.00	-320	-168	-4880	175	123	2970
15	140100	14.01	-350	-186	-5360	179	128	3070

$\nu = \frac{\text{Lateral micro stain}}{\text{Axial micro Strain}}$

$$= 1150/2530=0.45$$

30 % TYRE FIBRE

Table 6.6

S. #	Load	Stress	S ₁	S ₂	A. M. S	S ₃	S ₄	L.M.S
1	0	0	0	0	0	0	0	0
2	10126	1.01	-1	-36	-360	56	0	
3	19963	1.99	-3	-39	-400	78	5	
4	30351	3.03	-7	-41	-480	89	9	
5	40017	4.00	-17	-49	-660	90	15	
6	50495	5.04	-18	-52	-700	90	20	
7	60090	6.00	-22	-60	-820	90	30	
8	69990	6.99	-34	-90	-1250	99	40	
9	80900	8.09	-57	-91	-1480	109	57	57
10	89699	8.96	-63	-96	-1590	106	58	
11	99997	9.99	-92	-101	-1930	120	59	
12	111560	11.15	-101	-106	-1980	120	59	
13	119050	11.90	-110	-110	-2110	123	60	
14	130070	13.00	-112	-119	-2290	123	88	
15	141000	14.10	-127	-170	-2820	124	95	
16	151120	15.11	-130	-171	-2980	139	98	
17	161030	16.10	-130	-171	-3010	143	99	
18	170000	17.00	-135	-190	-3200	150	105	

19	180030	18.00	-139	-190	-3250	163	107	
20	190510	19.05	-142	-191	-3300	178	115	
21	200520	20.05	-147	-191	-3330	188	115	
22	210290	21.02	-155	-200	-3470	189	118	
23	220040	22.00	-162	-201	-3560	195	120	
24	230250	24.00		-321	-4840	215	190	
25	246690							

$$\nu = \frac{\text{Lateral micro stain}}{\text{Axial micro Strain}}$$

$$= \frac{57}{1480}$$

$$= 0.038$$

Due to experimental inaccuracies, this result is too small and therefore it may be discarded.

Cylinders were also crushed and, the cylinder crushing strength was found to be 16.65 and 18.35N/mm² for 10% Tyre fibre specimens. 20% Tyre fibre specimen showed values of 21.26 & 18.98 N/mm². In case of 30% Tyre fibre value are 24.5, 28.41 & 27.9 N/mm².

From the above facts & figures, it appears that improvement is more pronounced in the cylinder than the cubes with the increase of Tyre fibre cylinder crushing results are presented in tables 5.7,5.8,5.9,5.10.

7. Modulus of Elasticity

Cylinder 1 - 10 % Tyre Fibre

Table 7.1

S. #	Load	Stress	S ₁	Difference	S ₂	Difference	Avg: x20
1	0	0	0	0	0	0	0
2	6340	14.35	1040	.15	770	-65	-500

$$\text{Crushing stress} = \text{Load/Area}$$

$$= \frac{73225}{4415.6}$$

$$= 16.65 \text{ N/mm}^2$$

$$E = \frac{14.35 \times 10^3}{500} = 28.7 \text{ K N/mm}^2$$

Cylinder 2 - 10 % Tyre Fibre

Table 7.2

S. #	Load	Stress	S ₁	Difference	S ₂	Difference	Avg: x20
1	0	0	871	0	832	0	0

2	70081	15.87	860	-11	821	11	220
---	-------	-------	-----	-----	-----	----	-----

Crushing stress = Load/Area

$$= \frac{81030}{4415.6}$$

$$= 18.35 \text{ N/mm}^2$$

$$E = \frac{15.87 \times 1000}{220} = 72.13 \text{ K N/mm}^2$$

Cylinder 1 - 20 % Tyre Fibre

Table 7.3

S. #	Load	Stress	S ₁	Difference	S ₂	Difference	Avg: x20
1	0	0	955	0	888	0	0
2	73350	16.6	934	-21	850	-1038	-590

Crushing stress = Load/Area

$$= \frac{93899}{4415.6}$$

$$= 21.26 \text{ N/mm}^2$$

$$E = \frac{16.6 \times 10^3}{220} = 28.14 \text{ K N/mm}^2$$

Cylinder 2 - 20 % Tyre Fibre

Table 7.4

S. #	Load	Stress	S ₁	Difference	S ₂	Difference	Avg: x20
1	0	0	1156	0	943	0	0
2	53099	12.02	1220	-64	935	-8	720

Crushing stress = Load/Area

$$= \frac{83830}{4415.6}$$

$$= 18.98 \text{ N/mm}^2$$

$$E = \frac{12.20 \times 10^3}{720} = 16.7 \text{ K N/mm}^2$$

Cylinder 1 - 30 % Tyre Fibre

Table 7.5

S. #	Load	Stress	S ₁	Difference	S ₂	Difference	Avg: x20
------	------	--------	----------------	------------	----------------	------------	-------------

1	0	0	1211	0	871	0	0
2	83340	18.87	1270	-59	820	-51	1100

Crushing stress = Load/Area

$$= \frac{108560}{4415.6}$$

$$= 24.5 \text{ N/mm}^2$$

$$E = \frac{8.87 \times 10^3}{1100} = 17.15 \text{ K N/mm}^2$$

Table 7.6 Cylinder 2 - 30 % Tyre Fibre

S. #	Load	Stress	S ₁	Difference	S ₂	Difference	Avg: x20
1	0	0	1209	0	842	0	0
2	95330	21.59	1230	-21	880	-38	590

Crushing stress = Load/Area

$$= \frac{1254160}{4415.6}$$

$$= 28.41 \text{ N/mm}^2$$

$$E = \frac{21.59 \times 10^3}{590} = 36.03 \text{ K N/mm}^2$$

Table 7.7 Cylinder 3 - 30 % Tyre Fibre

S. #	Load	Stress	S ₁	Difference	S ₂	Difference	Avg: x20
1	0	0	804	0	839	0	0
2	96880	21.9	830	-26	805	-34	-600

Crushing stress = Load/Area

$$= \frac{123540}{4415.6}$$

$$= 27.9 \text{ N/mm}^2$$

$$E = \frac{21.9 \times 10^3}{600} = 36.05 \text{ K N/mm}^2$$

The procedure adopted for this test was in accordance with the British code of practice BS1881-1970. In a few cases, due to experimental inaccuracies, the values were unrealistic, therefore, they were discarded. The remaining values are presented below

For 10% Tyre Fibre $E = 28.7 \text{ KN/mm}^2$, for 20% Tyre Fibre values are $E = 28.14 \text{ KN/mm}^2$. & 16.7 KN/mm^2 .

For 30% Tyre Fibre values are 17.15 KN/mm^2 , 36.03 KN/mm^2 & 35.6 KN/mm^2 . This shows that the value of E is not affected drastically with the addition of a smaller portion of Tyre Fibre but the effect is more pronounced when Tyre material is in the range of 30%.

8. POISSON'S RATIO:

Poisson's ratio for 0% Fibre was found to be 0.38 as shown in tables:5.3.1 to 5.3.3

Batch # 1 With 0% Tyre Fibre

Table 8.1

S. #	Poisson's Ratio	Avg:
1	0.37	0.382
2	0.486	
3	0.29	

Batch # 2 With 20% Tyre Fibre

Table 8.2

S. #	Poisson's Ratio	Avg:
1	0.45	0.37
2	0.29	

Batch # 3 With 30% Tyre Fibre

Table 8.3

S. #	Poisson's Ratio	Avg:
1	0.038	0.1185
2	0.199	

It shows a slight reduction from 0.382 to 0.37% in case of 20% Tyre Fibre, however, here again, a very drastic effect is observed in the case of 30% Tyre Fibre with

$V = 0.12$

9. ULTIMATE STRAIN IN BENDING

Because with no steel bars or vertical stirrups were tested by applying a single point load at the centre. The effective span was 900 mm. The beams were simply supported and results are presented in Table9.1.

Table 9.1

S. #	Fibre %	M (N-mm)	Z mm	$\sigma \text{ N/mm}^2$	Remarks
1	10%	414000	83333	4.9	
2	20%	724500	83333	8.69	
3	30%	1035000	83333	12.42	

From the table, it can be observed that the ultimate stress due to bending improves quite a lot with the increase of the ratio of the Tyre Fibre. It almost triples when the ratio increases from 10% to 30%. This is a positive point & surely this will have a very favourable effect on the behaviour of the beams in terms of ductility.

6. Summary of results

Property	Fibre Percentage			Remarks
	10%	20%	30%	
Cube Crushing Strength N/mm ²	*	*	24	Concrete Grade M15
Cylinder Crushing Strength N/mm ²	18.35	21.26	28.41	Concrete Grade M15
Modulus of Elasticity KN/mm ²	*	28	36.05	
Poisson's Ratio	0.382	0.37	0.1185	B/W 0.1 For High Strength 0.2 For Weak Mixes
Ultimate Flexural Stress N/mm ²	4.9	8.69	12.42	Increasing with the fibre increase

* Due to experimental inaccuracies, some of the results were discarded.

7. Conclusion

Cube crushing strength does not show appreciable improvement of strength except when the Tyre Fibre ratio is in the range of 30%.

Cylinder crushing strength shows substantial improvement with the increase of the ratio of Tyre Fibre at every percentage.

Modulus of elasticity also shows a drastic increase only in the case of 30% Tyre Fibre.

Poisson's ratio decreases quite a lot when the Tyre Fibre is 30%. Otherwise, at a lower percentage, the effect is negligible.

The improvement of ultimate flexural stress is quite good at every percentage.

8. Suggestions

8.1. The experimental study, the results of which are presented in this thesis is very limited in scope. A further study may help in understanding various other dimensions of the fibre reinforced cement concrete.

8.2. Therefore, it is proposed that more specimens may be tested before arriving at a final conclusion.

8.3. The scope of this study may be enhanced further by increasing the tyre Fibre ratio beyond 30%.

8.4. Flexural behaviour may also be studied in terms of load-displacement history.

8.5. Reinforced concrete beams designed for shear failure could be tested to find the effect of tyre Fibre on shear strength of beams.

8.6. The behaviour of scrap tyre rubber concrete may be checked in extreme temperatures in future studies

REFERENCES

[1] Samarrai, Mufid A. & Elvery Robert H, (1974). "The influence of fibres upon crack development in reinforced concrete subject to uniaxial tension", Magazine of Concrete Research, Volume 26, Issue 89, 203-211.

[2] Rajagopalan. K., Parmasivam & Ramaswamy G.S. (1974). "Strength of Steel Fibre Reinforced Concrete Beams", Indian Concrete Journal, Volume 48, Issue 1, 17-25.

[3] Hannant, D.J (1976). "Additional data on fibre corrosion in cracked beams and theoretical treatment of the effect of fibre corrosion on beam load capacity", RILEM, Volume 2,533-538.

[4] Gasparini, D. A., Verma, D., & A., Abdallah, "Post cracking Tensile Strength of Fibre Reinforced Concrete", ACI's Materials Journal, Volume 86, Issue 1, 10-15.

[5] George Nammur Jr. & Antoine E. Naaman, (1989), "Bond Stress Model for Fibre-Reinforced Concrete Based on Bond Stress-Slip Relationship", ACI's Materials Journal, Volume 86, Issue 1, 45-57.